

APMO5032

Features:

- cost effective
- ultra miniature size
- shock and vibration resistant

Specifications						
Parameter	Symbol	Condition	Min	Typ	Max	Unit
Frequency	$f_0$	Single frequency	1		150	MHz
Frequency Tolerance	$\Delta f$	Includes frequency variations due to initial tolerance, temperature and power supply voltage			$\pm 10, \pm 25, \pm 50$	ppm
Aging	$\Delta f$	1 year @25°C				ppm
Supply Current, standby	$I_{DD}$	T=25°C				
Output Logic Levels					15	uA
Output logic high	$V_{OH}$	-4mA	$0.8 * V_{DD}$			
Output logic low	$V_{OL}$	4mA			$0.2 * V_{DD}$	volts
Output Startup Time2	$t_{SU}$	T=25°C		1.0	1.3	ms
Output Disable Time	$t_{DA}$			20	100	ns
Output Duty Cycle	SYM		45		55	%
Input Logic Levels						
Input logic high	$V_{IH}$		$0.75 * V_{DD}$			volts
Input logic low	$V_{IL}$				$0.25 * V_{DD}$	

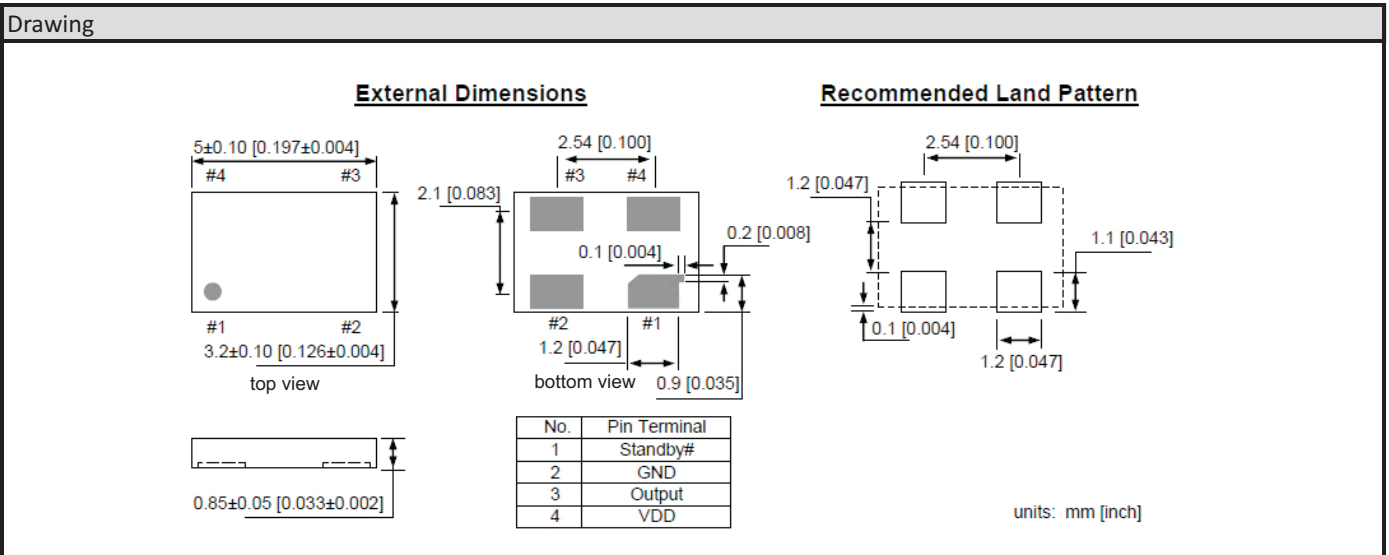

## VDD = 1.8V

Parameter	Symbol	Condition		Min	Typ	Max	Unit
Supply Current, no load	$I_{DD}$	$C_L=0p$	1MHz		6.0	6.3	mA
		$R_L=?$	27MHz		6.5	6.9	
		$T=25^{\circ}C$	70MHz		7.2	7.5	
			150MHz		8.3	9.1	
Output Transition time							
Rise Time	$t_R$	$C_L=15pF; T=25^{\circ}C$			1.8	3.0	ns
Fall Time	$t_F$	20%/80%* $V_{DD}$			1.0	3.0	
Jitter, Max Cycle to Cycle	$J_{CC}$	$F = 100MHz^3$			60.0		ps

## VDD = 2.5V

Parameter	Symbol	Condition		Min	Typ	Max	Unit
Supply Current, no load	$I_{DD}$	$C_L=0p$	1MHz		6.0	6.3	mA
		$R_L=?$	27MHz		6.7	7.0	
		$T=25^{\circ}C$	70MHz		7.7	8.1	
			150MHz		9.6	10.6	
Output Transition time							
Rise Time	$t_R$	$C_L=15pF; T=25^{\circ}C$			1.0	2.0	ns
Fall Time	$t_F$	20%/80%* $V_{DD}$			0.9	2.0	
Jitter, Max Cycle to Cycle	$J_{CC}$	$F = 100MHz^3$			50.0		ps

## VDD = 3.3V

Parameter	Symbol	Condition		Min	Typ	Max	Unit
Supply Current, no load	$I_{DD}$	$C_L=0p$	1MHz		6.0	6.3	mA
		$R_L=?$	27MHz		6.8	7.2	
		$T=25^{\circ}C$	70MHz		8.2	8.7	
			150MHz		10.8	12.2	
Output Transition time							
Rise Time	$t_R$	$C_L=15pF; T=25^{\circ}C$			1.0	2.0	ns
Fall Time	$t_F$	20%/80%* $V_{DD}$			0.9	2.0	
Jitter, Max Cycle to Cycle	$J_{CC}$	$F = 100MHz^3$			50.0		ps

## Solder Reflow Profile

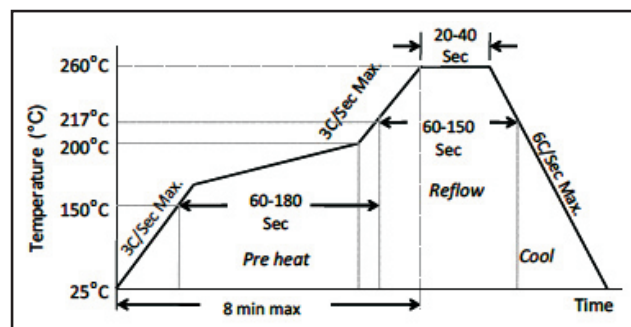

## Order key

O	- 10.000000M	- APMO 5032	- 50	- 3.3	- A	-	/	T
Part	Frequency	Type	Tolerance	Voltage	Temperature	Load	Option	Packaging
O=Oscillator	M=MHz	APMO=Programmable Quartz oscillator	±ppm	3.3=3.3Volt 2.5=2.5Volt 1.8=1.8Volt	A= 0°C ~ +70°C B= -10°C ~ +60°C C= -10°C ~ +70°C D= -20°C ~ +70°C E= -40°C ~ +85°C	blank = 15pF	T=Tristate	Tube
		APMO 5032=SMD 5.0x3.2						